

EC3-D72 with TCP/IP Communication Capability

EC3-D72 is the superheat controller with TCP/IP connection for step-per motor driven Electrical Control Valves EX4...EX6 and is optimized to operate with the Copeland Digital Scroll series utilising a 0-10V input from a third party controller. The controller synchronises the PWM digital compressor solenoid valve with the superheat controlled by the electrical control valve; EX series.

Note: This document contains short form instructions for experienced users.

SAFETY INSTRUCTIONS

- Read installation instructions thoroughly. Failure to comply can result in device failure, system damage or personal injury.
- The product is intended for use by persons having the appropriate knowledge and skills.
- Disconnect all voltages from system before installation.
- Do not operate system before all cable connections are completed.
- Comply with local electrical regulations when wiring.

Note: The EC3-D72 series contains a lead, acid gel rechargeable battery. The battery must NOT be disposed of with other commercial waste. Instead, it is the user's responsibility to pass it to a designated collection point for the safe recycling of batteries (harmonised directive 98/101/EEC). For further information contact your local environmental recycling center.

TECHNICAL DATA

Power supply	24VAC ±10%; 50/60Hz; 1A
Power consumption	25VA max. including EX4 ... EX6
Plug-in connector	Removable screw terminals wire size 0,14 .. 1,5 mm ²
Grounding	6,3 mm spade earth connector
Protection class	IP20
COM, TCP/IP connection	RJ45 Ethernet
Connection to optional local ECD-002	ECC-N30 or CAT5 cable with RJ45 connectors
Digital Input;	0/24VAC/DC for stop/start function. EX valve closes during stop command. Typically thermostat or third party controller.
Cooling demand	
Digital Input;	0/24VAC/DC typically connected to auxiliary connection.
Comp2 running	EX valve control loop remains active when input is 24V and the digital scroll is idle.
NTC input; Coil-out	Emerson temperature sensor ECN-N60 or ECN-P60 temperature sensor
4-20 mA Analog input	Emerson PT5-07M / PT5-18M / PT5-30M
4-20 mA Analog output	For connection to any 3rd party controller with 12/24VDC
Deviation from input signal	power supply and appropriate burden ±8% max
Output alarm relay	SPDT contact 24V AC/DC, 2 Amp inductive load (If L2 = 1) Activated: ... During normal operation (no alarm condition) Deactivated: ... During alarm condition or power supply is OFF
Output pump down relay	SPDT contact 24V AC/DC, 2 Amp inductive load (If L2 = 1) Activated: ... During normal operation Deactivated: ... All other conditions
WARNING: If the output relays are not utilized, the user must ensure appropriate safety precautions are in place to protect the system against damage caused by a power failure.	
Output Digital Scroll	24V or 230V AC output to activate PWM Digital Scroll Triac
Stepper motor output	Maximum current 0.6A with nominal 24VDC operating voltage for EX4...EX6
Ambient temperature	32 – 140°F
range	34 – 77°F (for best battery life time) > 95°F; battery life time < 2 years
In order to provide system protection in the event of power loss, it is recommended to change the battery annually.	



EC3-D72

MOUNTING

- The EC3-D72 is designed to be mounted onto a standard DIN rail.

ELECTRICAL INSTALLATION

- Refer to the electrical wiring diagram for electrical connections.
- Do not apply voltage to the controller before completion of wiring.
- Ground the metal housing with a ¼" spade connector.
- **Important:** Keep controller and sensor wiring well separated from mains wiring. Minimum recommended distance 1.2".

WARNING: Use a class II category transformer for 24VAC power supply. Do not ground the 24VAC lines. We recommend using individual transformers for EC3 controller and for 3rd party controllers to avoid possible interference or grounding problems in the power supply. Connecting any EC3 inputs to mains voltage will permanently damage the EC3.

WIRING

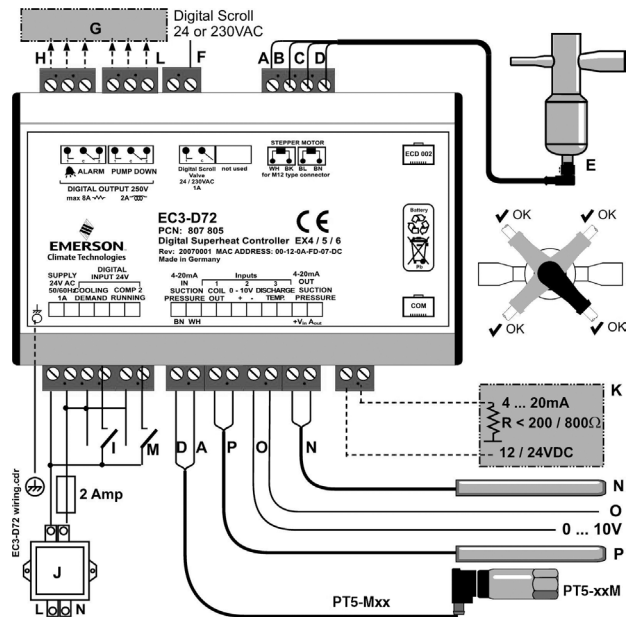

- A: White B: Black C: Blue D: Brown
- E: M12 Plug cable assembly EX5-Nxx for connection to EX4/EX5/EX6
- F: 24V/230V Triac output to PWM Digital Scroll valve
- G: Remote control panel, system controller
- H: Alarm relay, dry contact. Relay coil is not energised at Alarm or power off
- I: Digital input 1: "Cooling demand" (Digital compressor run: (0V/open = Stop; 24V/closed = Control Start;)
- J: Transformer Class II, 24VAC secondary / 25VA min. Model ECT-323
- K: Third party controller (can use the suction pressure (4-20mA) analog output signal from EC3)
- L: Pump down relay, dry contact. Relay is energized during normal operation.
- M: Digital input 2: "Comp. 2 running" (0V/ open = Comp2 stop; 24V/closed = Comp2 running
- N: Discharge Temp. Sensor
- O: 0-10V Digital Scroll capacity demand signal from system controller
- P: ECN-N60 Coil out sensor

Digital input status is dependent to operation of compressor/0-10V input

System Operating Condition	Digital Inputs	0-10V Input from Third Party Controller
Comp. 1 & Comp.2 in stop mode	"Cooling demand" open (0V) "Comp 2 Running" open (0V)	ECV remains closed irrespective of voltage input value
Comp. 1 in run & Comp. 2 in stop mode	"Cooling demand" closed (24V) / "Comp 2 Running" open (0V)	ECV active Input =0V: digital valve capacity at 10% default capacity. When the digital comp. is in by-pass the ECV will: Close when capacity is <70% Be inhibited when the capacity is >70%
Comp. 1 & Comp. 2 in run mode	"Cooling demand" closed (24V) / "Comp 2 Running" closed (24V)	ECV active The ECV will always modulate even when the digital compressor is in by-pass mode.
Comp. 1 in stop & Comp. 2 in run mode starts	"Cooling demand" open (0V) / "Comp 2 Running" closed (24V)	ECV remains closed irrespective of voltage input value.

Digital comp. should always be regarded as base load; compressor 1

PREPARATION FOR START-UP

- Vacuum the entire refrigeration circuit.

WARNING: Electrical Control Valves EX4...EX6 are delivered at half open position. Do not charge system before closure of valve.

- Apply supply voltage 24V to EC3 while the cooling demand digital input is 0V (open). The valve will be driven to close position.
- After closure of valve, start to charge the system with refrigerant.

POSSIBILITIES OF CONNECTING EC3-D72 TO A NETWORK OR PC

A TCP/IP Controller Readme file is available on the www.emersonclimate.eu website to provide detailed information about TCP/IP Ethernet connectivity. Please refer to this file if you need information beyond the contents of this instruction sheet.

- 1) Connect the EC3-D72 using the optional ECC-N30 cable assembly or a standard CAT5 network cable with RJ45 plugs assembly to a network or router that enables the controller to receive a dynamic TCP/IP address or
- 2) Connect the EC3-D72 to a computer using a crossover cable plugged directly into the Ethernet port. In this case, the TCP/IP address of the computer must be manually modified to be compatible with the default address of the controller. Refer to the TCP/IP Controller-Readme file for more details.

SETTING AND VISUALIZING DATA: WEBPAGES (RECOMMENDED METHOD)

Important: Make sure that cooling demand input is 0V (open). Turn the power supply ON.

Four parameters i.e. refrigerant type (u0), pressure sensor type (uP), valve type (ut) and control mode can be set only when cooling demand digital input is open (0V) and the power supply is ON (24V). This feature is for added safety to prevent accidental damage of compressors and other system components. All other parameters can be modified at any time. The EC3-D72 has a TCP/IP Ethernet communication interface enabling the controller to be directly connected to a network or a PC via the standard Ethernet port. The EC3-D72 controller has embedded WebPages to enable the user to visualise the parameter lists using real text labels.

To view WebPages on the PC, a standard WebBrowser like Internet Explorer® or Mozilla Firefox and JRE Java Runtime Environment is needed. JRE can be downloaded at no charge from the www.java.com website. Open the Internet browser program on the computer and, if EC3-D72 is connected directly to PC with a crossover cable enter the default TCP/IP address of the controller (192.168.1.101) into the address line, or the dynamic address from the DHCP server from network/Router. Refer to the TCP/IP Controller-Readme file if a specific port is required.

It is possible to identify the dynamic TCP/IP address assigned by DHCP of the Router or network, refer to the TCP/IP Controller-Readme file.

After a few moments, the default monitoring page should be displayed. If the browser does not open the default page or display active data, the user should check the Internet browser "Option" configuration. Refer to the TCP/IP Controller-Readme file.

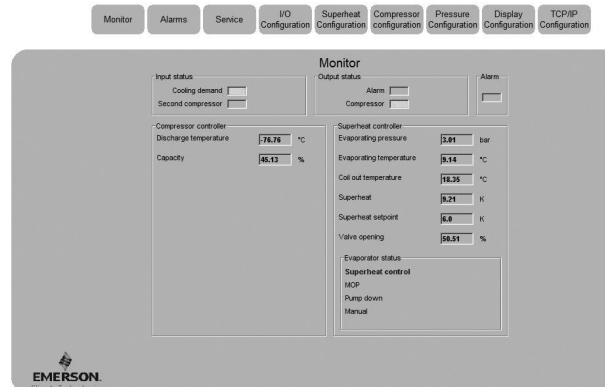

The Monitoring and Alarm WebPages are read only and therefore it is not necessary to enter a username or password. A username and password will be requested upon the initial request to any of the other WebPages.

The factory default settings are :

Username: "EmersonID" , Password: "12"

The default settings may be modified on the Display configuration page.

Press the tabs at the top of the Monitoring page with a left click of the mouse button to enter the respective Webpage.

The parameters will be visualised in real text together with the program code as defined in the parameter list below.

After the parameters have been modified, the complete list of settings can be saved to the memory of the computer and used later to upload into another controller. This can save a considerable amount of time when using multiple controllers and over a period of time, a library can be created containing the parameter lists for equipment for different applications. It is also possible to display live graphical data from the controller.

Superheat, evaporating pressure, coil-out temperature and evaporating temperature are available on a 10 minutes rolling chart. Refer to the TCP/IP Controller-Readme file for a complete description of the features available for the TCP/IP series of controllers.

ECD-002 DISPLAY/KEYPAD UNIT (LEDs and Button Functions)

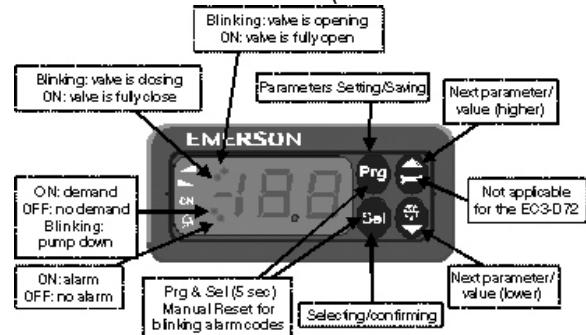

ALTERNATIVE PROCEDURE FOR PARAMETER MODIFICATION USING ECD-002

Note: Some of the functions/parameters (manual control and TCP/IP configuration) cannot be modified when using ECD-002 comparing to a set-up by PC via TCP/IP. **Warning:** All alarms are disabled during manual control. We do not recommend unattended operation of system during manual control.

The parameters can be accessed via the 4-button keypad. The configuration parameters are protected by a numerical password. The default password is "12". To select the parameter configuration:

- Press the **PRG** button for more than 5 seconds
A flashing 0 is displayed
- Press **▲** or **▼** until the password is displayed (default 12).
If the password was changed, select the new password
- Press **SEL** to confirm password
- Press **▲** or **▼** to show the code of the parameter that has to be changed;
- Press **SEL** to display the selected parameter value;
- Press **▲** or **▼** to increase or decrease the value;
- Press **SEL** to temporarily confirm the new value and display its code;

Repeat the procedure from the beginning "press **▲** or **▼** to show..."



To exit and save the new settings:

Press **PRG** to confirm the new values and exit the parameters modification procedure.

To exit without modifying any parameters:







Do not press any button for at least 60 seconds (TIME OUT).

LIST OF PARAMETERS IN SCROLLING SEQUENCE BY PRESSING  BUTTON

Code	Parameter description and choices	Min	Max	Factory setting	Field setting
H5	Password	1	199	12	
u0	System refrigerant 0 = R22; 1 = R134a; 2 = R507; 3 = R404A; 4 = R407C; 5 = R410A; 6 = R124; 7 = R744 (subcritical application)	0	7	4	
uP	Installed pressure sensor type 0 = PT5-07M (for R22/R134a/R507/R404A/R407C/R124) 1 = PT5-18M (for R410A) 2 = PT5-30M (for R744, subcritical)	0	2	0	
ut	Installed valve type 1 = EX4; 2 = EX5; 3 = EX6	1	3	2	
uu	Start valve opening (%)	10	100	50	
u9	Start opening duration (second)	1	30	5	
uL	Low superheat alarm function 0 = disable (for flooded evaporator) 1 = enable auto reset 2 = enable manual reset Cut-out at 0.5K (if it maintains 1 min.); Cut-in immediately at 3K	0	2	1	
u5	Superheat set-point (°F) If uL enabled (auto or manual) If uL disabled	5.4 0.9	54 54	10.8 10.8	
u2	MOP function 0 = disable 1 = enable	0	1	1	
u3	MOP set-point (°F) saturation temperature * * X Factory setting is according to selected refrigerant (u0): +55°F for R22; +59°F for R134a; +45°F for R507 +45°F for R404A; +59°F for R407C; +59°F for R410A +122°F for R124; +23°F for R744				
 5	Units conversion 0 = °C, K, bar; 1 = °F, R, psig (Psig values are divided by 10. Example: Display 12.5 is 125 psig)	0	1	0	
 1	Value to show 0 = Measured superheat (°F); 1 = Measured evaporator pressure (psig) 2 = Valve opening (%); 3 = Measured coil-out temp. (°F) 4 = Calculated evaporating temperature (°F) from the pressure 5 = Compressor capacity in %	0	4	0	
u4	Superheat control mode 0 = Standard, 1 = Slow	0	1	0	
uH	High superheat alarm function 0 = disable, 1 = enable auto reset	0	1	0	
uA	High superheat alarm setpoint	16	40	30	
ud	High superheat alarm delay, min.	1	15	3	
P2	Freeze protection cut-out, °F	-40	104	-32	
P3	Freeze protection cut-in, °F	-35	109	37	
P4	Freeze protection alarm function 0 = disable, 1 = enable auto-reset, 2 = enable manual reset	0	2	0	
P5	Freeze protection alarm delay, sec.	5	199	30	
P6	Pump-down function 0 = disable, 1 = enable auto-reset	0	1	0	
P7	Pump-down cut-out, psig	-7.3	261.1	7.2	
P8	Pump-down time delay, sec.	0	199	30	
P9	Low pressure alarm function 0 = disable, 1 = enable auto-reset, 2 = enable manual reset	0	2	0	
PA	Low pressure alarm cut-out, psig	-11.6	256.7	0	
Pb	Low pressure alarm delay, sec.	5	199	5	
Pd	Low pressure alarm cut-in, psig	-7.3	261.1	4.3	

SPECIAL FUNCTIONS

Special Functions can be activated by:

- Press  and  together for more than 5 seconds. A flashing 0 is displayed.
- Press  or  until the password is displayed (default = 12). If password was changed, select the new password.
- Press **SEL** to confirm password. A 0 is displayed and the Special Function mode is activated.
- Press  or  to select the function. The number of special functions is dynamic and controller dependent. See list below.
 - 0: Reset controller to factory settings (this action is possible only when digital input is 0V i.e. open)
 - 1: Displays the current TCP/IP address
 - 2: Assign temporary 192.168.1.101 as TCP/IP address if EC3-D72 has different address
- Press **SEL** to activate the function without leaving the special function mode.
- Press **PRG** to activate the function and leave the special function mode.

LIST OF PARAMETERS IN SCROLLING SEQUENCE BY PRESSING  BUTTON

Code	Parameter description and choices	Min	Max	Factory setting	Field setting
L2	Output logic 0: Alarm & pump down. = normal; 1: Alarm = inverse, pump down. = normal 2: Alarm = normal, pump down. = inverse; 3: Alarm & pump down. = inverse	0	3	1	
b1	Battery error management, when battery is defective, see below:	0	3	2	*
Value	Alarm display	Alarm relay	Valve	Reset possibility after recovery/replacement	
0	-	-	Regulating	-	
1	Ab	-	Regulating	-	
2	Ab	Signalling	Fully close	Auto	
3	Ab (blinking)	Signalling	Fully close	Manual	
Code	Parameter description and choices	Min	Max	Factory setting	Field setting
/6	Show decimal point; 0=yes, 1 = no	0	1	0	
A6	Maximum discharge temperature; °F	212	284	266	
A7	Discharge temp. alarm delay; sec.	0	199	30	
F2	Minimum capacity; %	10	100	10	
F3	Maximum capacity; %	10	100	100	
F6	Scroll Valve, PWM cycle time; sec.	10	20	20	
t3	Monitor discharge temperature sensor 0 = no, 1 = Yes	0	1	0	
ru	0-10V input filtering; 0 = off, 1 = on	0	1		

** Min. and Max. setting values are dependent upon selected type of refrigerant.*

Control (Valve) Start-Up Behavior (Parameter uu and u9)

$EX4/5/6 \leq 1.5 \text{ seconds}$

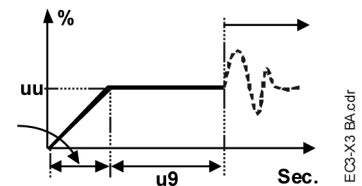

PUMP DOWN FUNCTION (IF P6=1 AND L2=1)

Cooling Demand Status	Alarm Condition	Pump Down Relay
24V (ON)	NO	Activate
0V (OFF)	NO	Deactivate when pressure drops below P7 and after elapsed time P8
0V or 24V	YES	Deactivate instantaneously

START-UP

Start the system and check the superheat and operating conditions. The EC3-D72 is fully functional without connected PC or keypad/display unit. ECD-002.

MOUNTING OF ECD-002

ECD-002 can be installed at any time also during operation.

- ECD-002 can be mounted in panels with 2.8 x 1.1 inch cutout
- Push controller into panel cut-out.(1)
- Make sure that mounting lugs are flush with outside of controller housing
- Insert Allen key into front panel holes and turn clockwise. Mounting lugs will turn and gradually move towards panel (2)
- Turn Allen key until mounting lug barely touches panel. Then move other mounting lug to the same position (3)
- Tighten both sides very carefully until keypad is secured. Do not over tighten as mounting lugs will break easily.

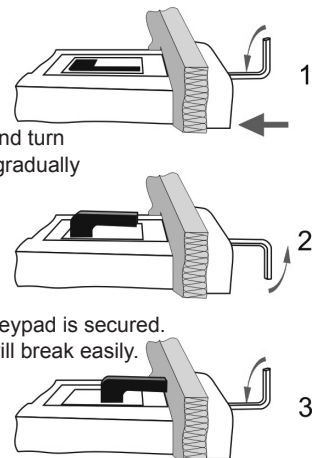

ERROR/ALARM HANDLING

Alarm code	Description	Related parameter	Alarm relay	Valve	What to do?	Requires manual reset after resolving alarm
E0	Pressure transmitter error	-	Signalling	Fully close	Check wiring connection and measure the signal 4 to 20 mA	No
E1	Coil-out temperature sensor error	-	Signalling	Fully close	Check wiring connection and measure the resistance of sensor	No
E3	Discharge temp. sensor error	-	Signalling	Regulating	Check wiring connections and measure the resistance of the sensor. Also check the status of the I/O configuration (t3)	No
AII	EX4 – EX6 electrical connection error	-	Signalling	-	Check wiring connection and measure the resistance of winding	No
Ab	Battery error	b1: 1	-	Regulating	Battery potentially does not have enough charge to close valve in case of main power supply interruption. May occur temporarily with new controllers or after long storage but should disappear when battery is charged sufficiently (allow 10hrs). If Ab remains active even when battery is charged, battery may be defective and should be replaced. (Replacement kit: 097693).	-
Ab		b1: 2	Signalling	Fully close		-
Ab blinking		b1: 3	Signalling	Fully close		Yes
AE blinking	Pump down action can not accomplished	P6: 1	Signalling	Already closed by Pumpdown command	Allocate the source, which does not let suction pressure drops below desired set-point	Yes
AF	Freeze protection	P4: 1	Signalling	Fully close	Check the system for cause of low pressure such as insufficient load on evaporator	No
AF blinking		P4: 2		Pumpdown deactivated		Yes
AL	Low superheat (<0,5K)	uL: 1	Signalling	Fully close	Check wiring connection and operation of valve	No
AL blinking		uL: 2		Pumpdown deactivated		Yes
AH	High superheat	uH: 1	Signalling	Fully close Pumpdown deactivated	Check the system	No
AP	Low pressure	P9: 1	Signalling	Fully close	Check the system for cause of low pressure such as refrigerant loss	No
AP blinking		P9: 2		Pumpdown deactivated		Yes
dA	High discharge temp.	A6: alarm setpoint	Signalling	Fully close Pumpdown deactivated	Check the system	No Fixed differential = 10°C
Er	Data error display – out of range	-	-	-	Data send to the display is out of range. Check temperature and pressure sensor.	No

Note: When multiple alarms occur, the highest priority alarm is displayed until being cleared, then the next highest alarm is displayed until all alarms are cleared. Only then will parameters be shown again.

Message

--- No data to display

The display will show an “---” at start up and when no data is being sent to the ECD-002

CHECKING SYSTEM OPERATING CONDITIONS USING LOCAL DISPLAY/KEYPAD ECD-002

The data to be permanently shown on the display can be selected by the user (parameter \downarrow 1). It is possible to temporarily display these values. However this function is not available in an alarm condition.

The display will show for one second the numerical identifier of the data (see \downarrow 1 parameter) and then the selected data. After 5 minutes, the display will return to the value selected by parameter \downarrow 1.

SERVICE/TROUBLESHOOTING

SYMPTOM	CAUSE	ACTION
Operating superheat is several degrees higher or lower than set-point	Incorrect signal from pressure or temperature sensors	1- Check the sensors 2- Make sure ECN-N60 temperature sensor is used 3- For optimum accuracy, please use: PT5-07M for R22/R134a/R507/R404A/R407C/R124 PT5-18M for R410A PT5-30M for R744 4- Make sure the sensor cables are not installed along with other high voltage cables
Operating superheat is too low; i.e. compressor wet running	1- Incorrect wiring of ECV 2- Defective sensors	1- Check the wiring 2- Check the sensor
Valve is not fully closed	1- The cooling demand digital input is ON (24V) 2- Wrong ECV selected	1- Valve is shut off only when the digital input is turned off (0V) 2- Check the setting of parameter ut
Unstable superheat (hunting)	Evaporator is designed to operate at higher superheat	Increase the superheat set-point to a higher value; if system is stable, start decreasing gradually, checking each time for a stable control
Valve opens when EC3 commands to close and vice versa	Wrong wiring between EC3-D72 and valve	Check the wiring and obey the color coding: white/black, blue/brown
Superheat set-point is shifting after several months of uninterrupted operation or permanent jumper of 24V digital input	Stepper motor driven valves require synchronization	Do not apply permanent 24V digital input. Interrupt digital input once every week for 5 seconds if compressor never stops. This has the effect of referencing the valve to the fully closed position

DIMENSIONS (IN INCHES)

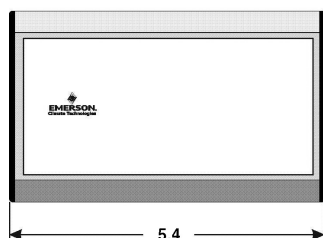

EC3-D72

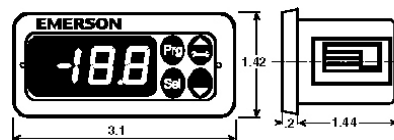
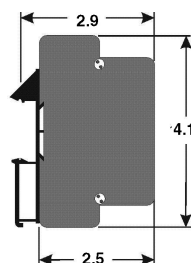

ECD-002

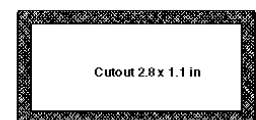

EmersonClimate.com/FlowControls

Technical Support: 1-866-625-8416